

- ★ Super Low Gate Charge
- ★ Green Device Available
- ★ Excellent Cdv/dt effect decline
- ★ Advanced high cell density Trench technology

Product Summary

BVDSS	RDSON	ID
-100V	0.65Ω	-1.5A

Description

The FKS0107 is the high cell density trenched P-ch MOSFETs, which provide excellent RDSON and gate charge for most of the synchronous buck converter applications.

The FKS0107 meet the RoHS and Green Product requirement with full function reliability approved.

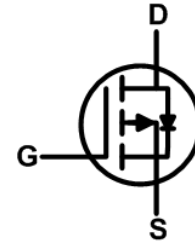
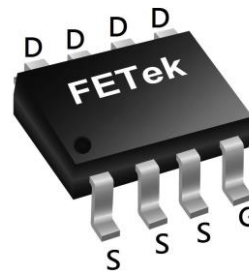
SOP8 Pin Configuration

Absolute Maximum Ratings

Symbol	Parameter	Rating	Units
V _{DS}	Drain-Source Voltage	-100	V
V _{GS}	Gate-Source Voltage	±20	V
I _D @T _A =25°C	Continuous Drain Current ¹	-1.5	A
I _D @T _A =70°C	Continuous Drain Current ¹	-1.2	A
I _{DM}	Pulsed Drain Current ²	-4.5	A
P _D @T _A =25°C	Total Power Dissipation ³	1.5	W
T _{STG}	Storage Temperature Range	-55 to 150	°C
T _J	Operating Junction Temperature Range	-55 to 150	°C

Thermal Data

Symbol	Parameter	Typ.	Max.	Unit
R _{θJA}	Thermal Resistance Junction-ambient ¹	---	85	°C/W
R _{θJC}	Thermal Resistance Junction-Case ¹	---	60	°C/W

**Electrical Characteristics ($T_J=25^\circ\text{C}$, unless otherwise noted)**

Symbol	Parameter	Conditions	Min.	Typ.	Max.	Unit
BV_{DSS}	Drain-Source Breakdown Voltage	$V_{GS}=0V, I_D=-250\mu A$	-100	---	---	V
$R_{DS(ON)}$	Static Drain-Source On-Resistance ²	$V_{GS}=-10V, I_D=-1A$	---	0.52	0.65	Ω
		$V_{GS}=-4.5V, I_D=-0.5A$	---	0.56	0.7	
$V_{GS(th)}$	Gate Threshold Voltage	$V_{GS}=V_{DS}, I_D=-250\mu A$	-1.0	-1.5	-2.5	V
I_{DSS}	Drain-Source Leakage Current	$V_{DS}=-80V, V_{GS}=0V, T_J=25^\circ\text{C}$	---	---	10	μA
		$V_{DS}=-80V, V_{GS}=0V, T_J=55^\circ\text{C}$	---	---	100	
I_{GSS}	Gate-Source Leakage Current	$V_{GS}=\pm 20V, V_{DS}=0V$	---	---	± 100	nA
gfs	Forward Transconductance	$V_{DS}=-5V, I_D=-1A$	---	3	---	S
Q_g	Total Gate Charge (-10V)	$V_{DS}=-50V, V_{GS}=-10V, I_D=-1A$	---	9.3	---	nC
Q_{gs}	Gate-Source Charge		---	1.75	---	
Q_{gd}	Gate-Drain Charge		---	1.25	---	
$T_{d(on)}$	Turn-On Delay Time	$V_{DD}=-50V, V_{GS}=-10V, R_G=3.3\Omega, I_D=-0.5A$	---	2	---	ns
T_r	Rise Time		---	18.4	---	
$T_{d(off)}$	Turn-Off Delay Time		---	19.6	---	
T_f	Fall Time		---	19.6	---	
C_{iss}	Input Capacitance	$V_{DS}=-15V, V_{GS}=0V, f=1\text{MHz}$	---	553	---	pF
C_{oss}	Output Capacitance		---	29	---	
C_{rss}	Reverse Transfer Capacitance		---	20	---	

Diode Characteristics

Symbol	Parameter	Conditions	Min.	Typ.	Max.	Unit
I_S	Continuous Source Current ^{1,4}	$V_G=V_D=0V$, Force Current	---	---	-1.5	A
V_{SD}	Diode Forward Voltage ²	$V_{GS}=0V, I_S=-1A, T_J=25^\circ\text{C}$	---	---	-1.2	V
t_{rr}	Reverse Recovery Time	$I_F=-1A, dI/dt=100A/\mu s, T_J=25^\circ\text{C}$	---	27	---	nS
Q_{rr}	Reverse Recovery Charge		---	36	---	nC

Note :

- 1.The data tested by surface mounted on a 1 inch² FR-4 board with 2OZ copper.
- 2.The data tested by pulsed , pulse width $\leq 300\mu s$, duty cycle $\leq 2\%$
- 3.The power dissipation is limited by 150°C junction temperature
- 4.The data is theoretically the same as I_D and I_{DM} , in real applications , should be limited by total power dissipation.

Typical Characteristics

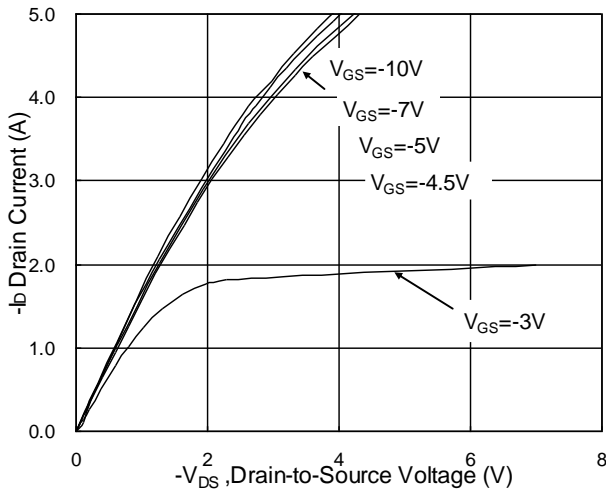

Fig.1 Typical Output Characteristics

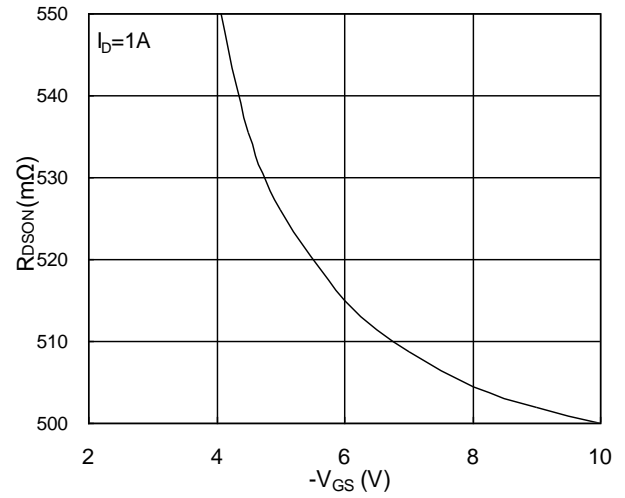

Fig.2 On-Resistance vs G-S Voltage

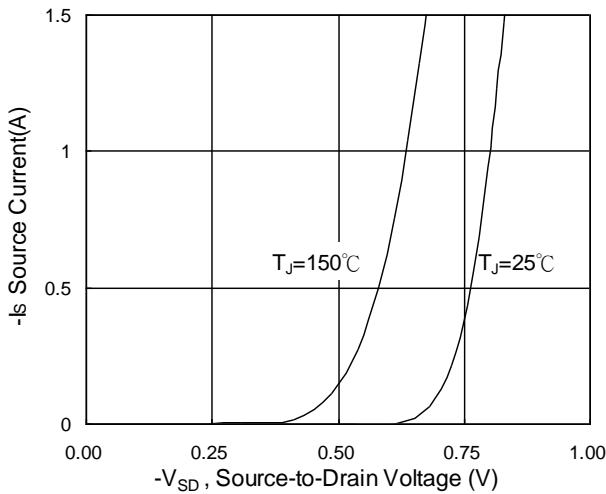

Fig.3 Source Drain Forward Characteristics

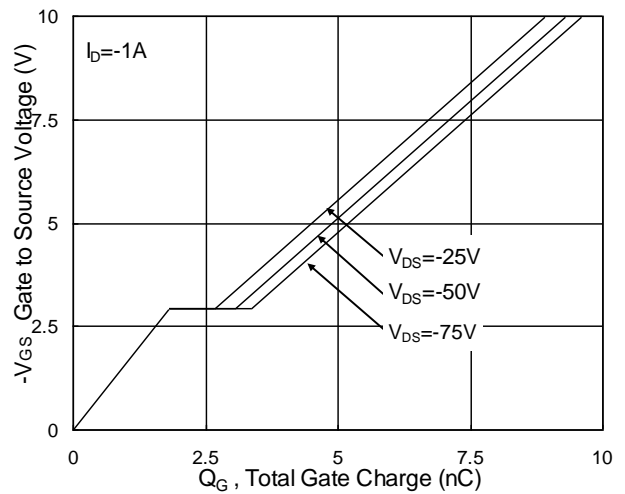

Fig.4 Gate-Charge Characteristics

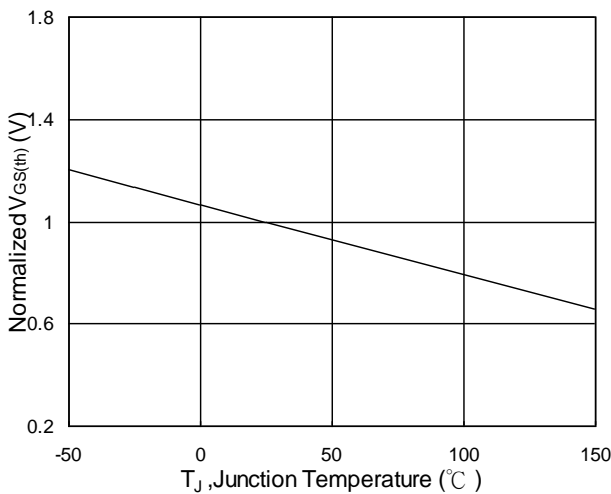

Fig.5 Normalized $V_{GS(th)}$ vs T_J

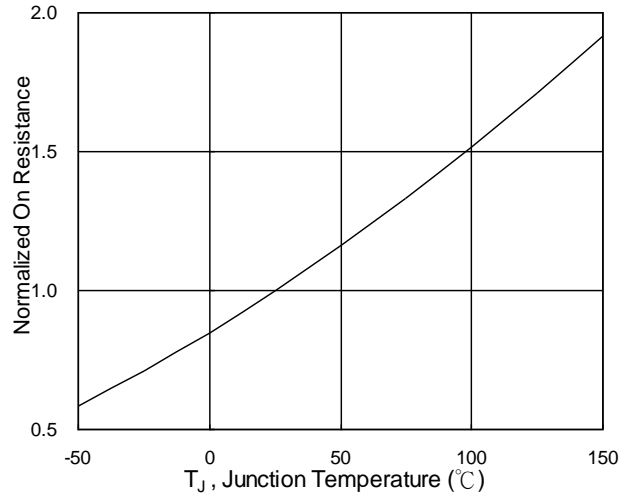

Fig.6 Normalized $R_{DS(on)}$ vs T_J

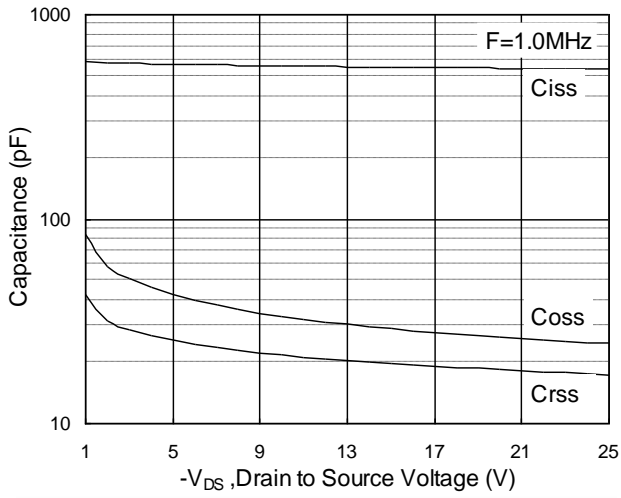

Fig.7 Capacitance

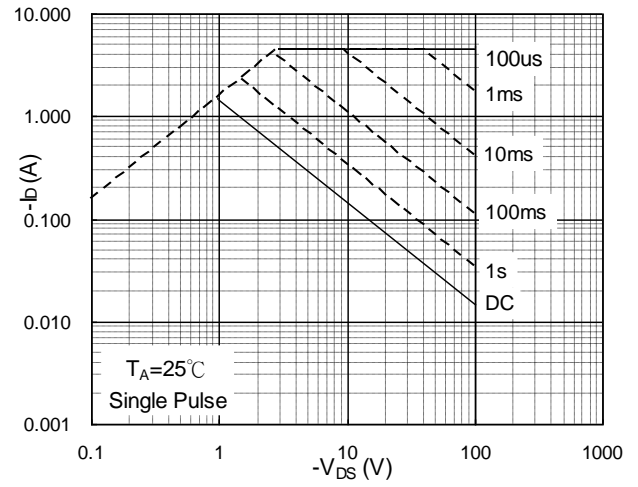

Fig.8 Safe Operating Area

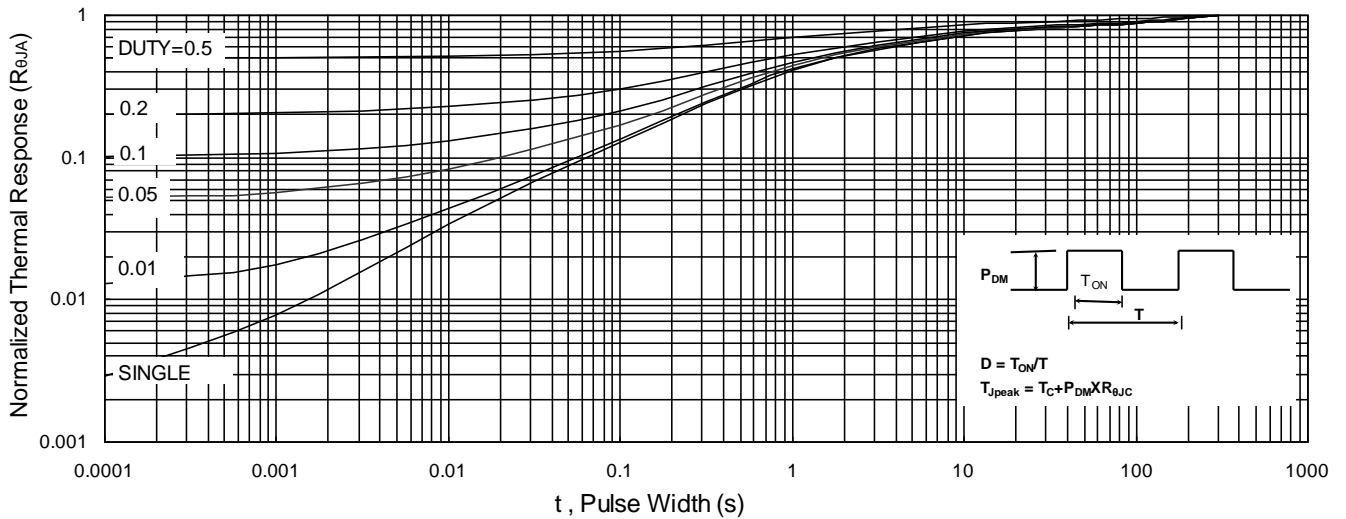

Fig.9 Normalized Maximum Transient Thermal Impedance

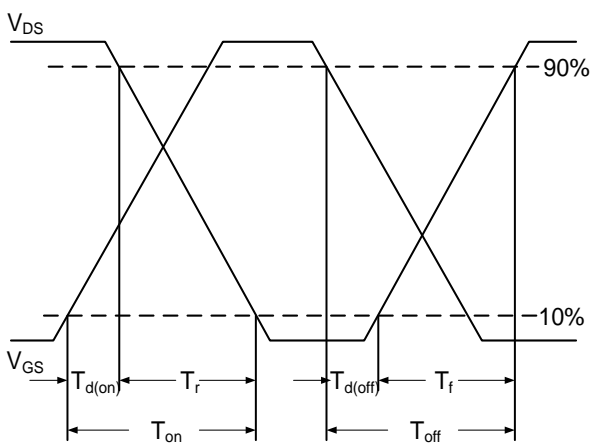

Fig.10 Switching Time Waveform

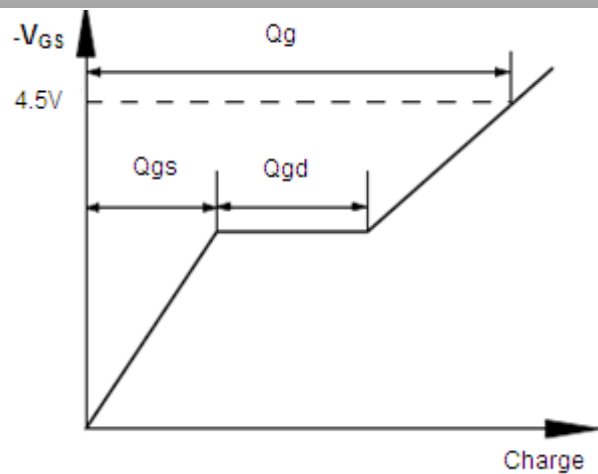
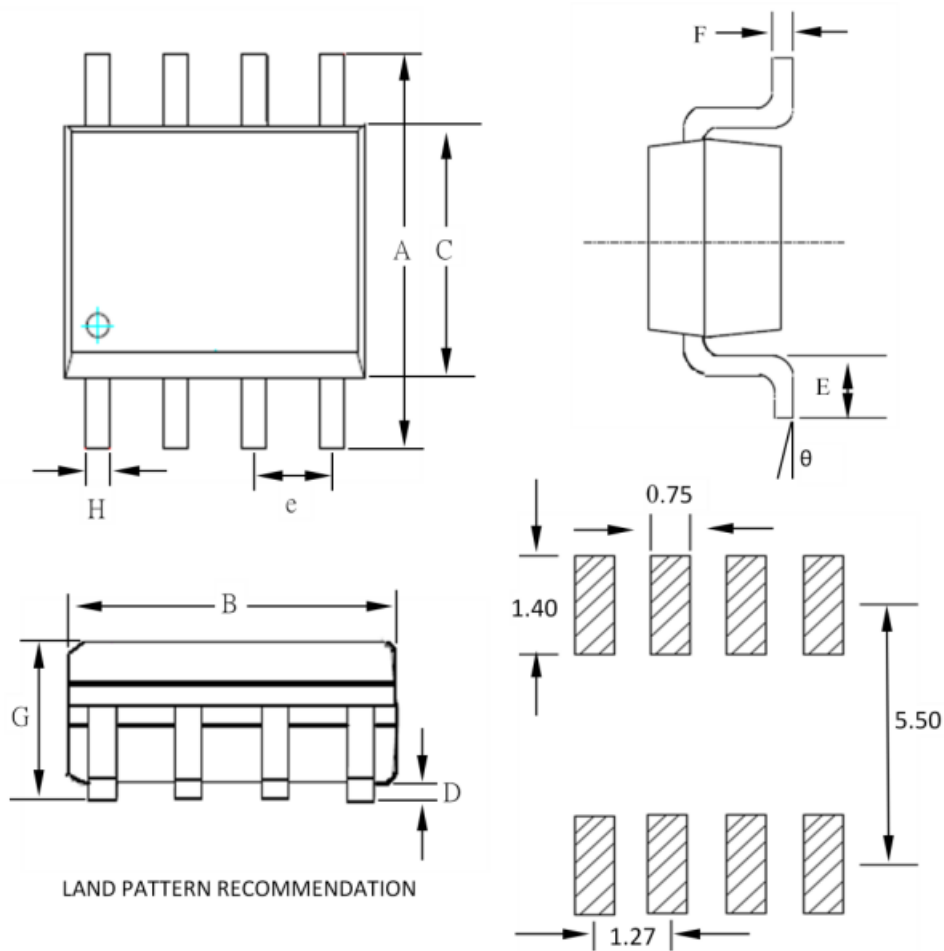

Fig.11 Gate Charge Waveform

SOP8 Package Outline Dimensions



SYMBOLS	MILLIMETERS			INCHES		
	MIN	NOM	MAX	MIN	NOM	MAX
A	5.75	6.00	6.25	0.226	0.236	0.246
B	4.70	4.90	5.15	0.185	0.193	0.203
C	3.70	3.90	4.10	0.146	0.154	0.161
D	0.05	--	0.25	0.002	--	0.010
E	0.40	--	1.27	0.016	--	0.050
F	0.16	--	0.25	0.006	--	0.010
G	1.23	--	1.75	0.048	--	0.069
e	1.07	1.27	1.47	0.042	0.050	0.058
H	0.31	--	0.51	0.012	--	0.020
θ	0°	--	8°	0°	--	8°

Marking Instruction

